



# Cameleon Dolly

DOLLIES

The HD400 is the fifth generation of the popular Cameleon Dolly, incorporating a powerful hydraulic accumulator system for smooth up and down boom movement.



## Cameleon Dolly Quick Specs

Length	46" (117cm)
Width	26" (66cm)
Front Platform Height	6" (15cm)
Rear Platform Height	14" (36cm)
Steering Post Height	39" (99cm)
Height with Steering Post Removed	20.5" (52cm)
Weight	235lbs (107kg)
Vertical Boom Travel	36" (91cm)
Maximum Boom Capacity	200lbs (91kg)
Maximum Dolly Capacity	700lbs (318kg)
Maximum Power Consumption	4 amps
Working Pressure	750-2000 PSI
Boom Lifts Per Charge	5
Electric Charging Time	100 seconds

**Partners in Production®**

VANCOUVER

CALGARY

WINNIPEG

TORONTO

SUDBURY

HALIFAX



# Cameleon Dolly

DOLLIES

## SPECIFICATIONS

LENGTH.....	46"	117 CM
WIDTH.....	26"	66 CM
FRONT PLATFORM HEIGHT.....	6"	15 CM
REAR PLATFORM HEIGHT .....	14"	36 CM
STEERING POST HEIGHT.....	39"	99 CM
HEIGHT WITH STEERING POST REMOVED.....	20.5"	52 CM
WEIGHT.....	235 LBS.	107 KG
VERTICAL BOOM TRAVEL.....	36"	91 CM
MAXIMUM BOOM CAPACITY.....	200 LBS.	91 KG
MAXIMUM DOLLY CAPACITY.....	700 LBS.	318 KG
MAXIMUM POWER CONSUMPTION.....	4 AMPS	
WORKING PRESSURE.....	750 TO 2000 PSI	
BOOM LIFTS PER CHARGE.....	5	
ELECTRIC CHARGING TIME.....	100 SECONDS	

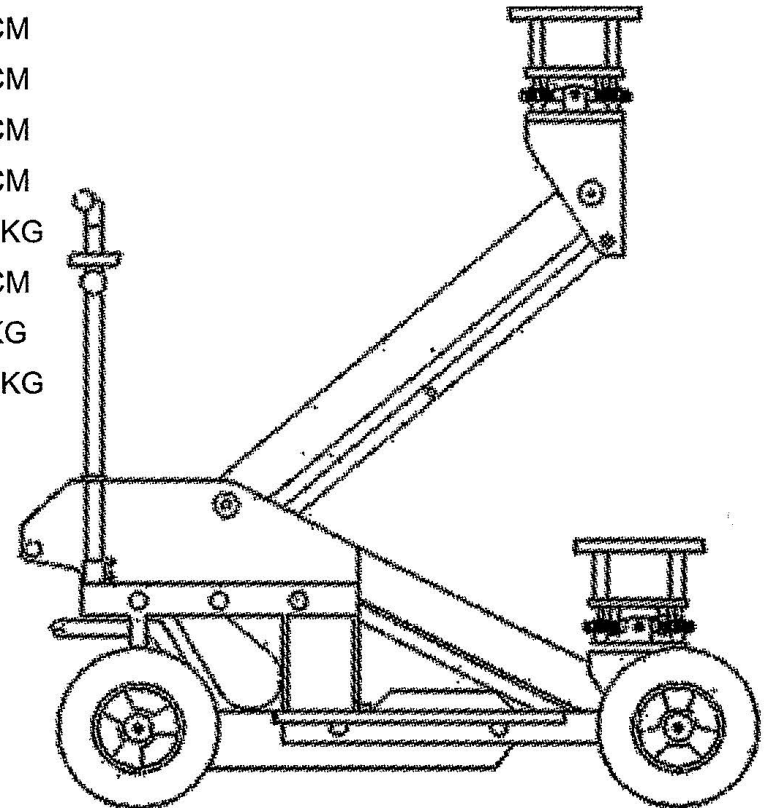

Partners in Production®

VANCOUVER

CALGARY

WINNIPEG

TORONTO

SUDBURY

HALIFAX